

GAP™

Graphical Application Programmer

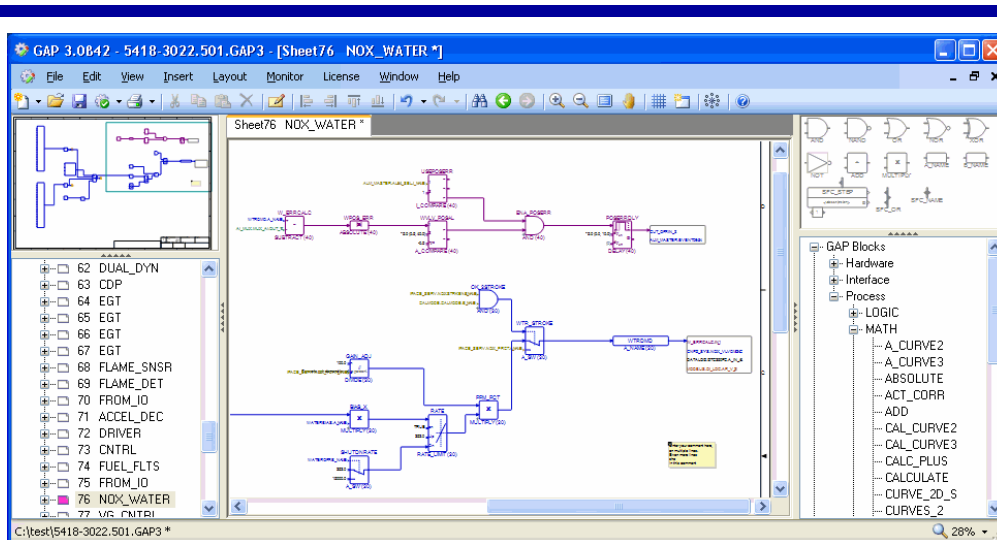

Application

Woodward's Graphical Application Programmer (GAP™) utilizes a fourth-generation language developed by Woodward. The self-documenting GAP software allows control engineers to custom design a control system for any application. Woodward has used GAP-created code since the mid 1980s. This high level machine language is in a block format, putting many lines of code in each block to achieve a desired function. The advantage of using a block format is that individual lines of code do not need to be debugged, since each program block has already been debugged during development, testing, and field applications.

Description

Woodward GAP is a Windows based software program that allows controls engineers to create block format application programs for a number of Woodward control systems. Once the control logic is entered using the program's graphical programming environment, the GAP software compiler function generates code that runs in the control.

GAP software blocks are written in C code, which is a transportable language, allowing it to be used on many different hardware platforms. Because of this feature, the same control logic software that has been used and proven in thousands of controls is available for use in the creation of future controllers, without introducing system bugs.

For ease of learning and use, the GAP software diagram entry screen has the look and feel of several software simulator tools familiar to many control engineers. Blocks much like the blocks used to enter models into MATLAB are entered into the GAP software.

The GAP software package is a mature programming package, providing revision control, security, and code import/export tools to facilitate program management and code re-use. GAP Modules allow multiple sections of control logic and algorithms to be created and controlled by different entities, then compiled into a single program for unit control.

- Designed for engine or turbine control engineers
- Minimal programming skills needed
- Windows® “.NET” based, block-oriented editor
- Self-generating C code
- GAP™ blocks are proven, tested software routines
- Powerful editing, navigation and documentation features
- Automatic change logging
- Allows MATLAB® / Simulink® * code importing
- Optional monitoring package available
- Optional trending package available
- Compatible with NetSim™ simulation tools

*—MATLAB and Simulink are trademarks of The MathWorks, Inc.

While the GAP block language has proven to be an extremely efficient means of programming a turbine controller, some users still require that their existing sequencing logic run on their new control. For these users, Woodward's Ladder Logic Programming tool can be used with GAP to create sequence logic via industry-standard ladder logic programming. This tool gives the user the capability to perform sequencing in Ladder Logic program language and to perform complex control algorithms in GAP. Like most industry standard ladder logic programs, this program also allows the user to make sequence changes while the engine is on or off line.

When designing and commissioning an engine control system, much time is often spent rewriting, retesting, and redrawing documentation for software that has already been proven in a similar application. GAP allows a control systems engineer to efficiently reuse software representing decades of experience and minimize repetitive documentation time.

Run-Time Performance

When many complex algorithms are implemented into a single controller, the result can sometimes be a less than robust controller. One of the main advantages of the GAP software is that all the blocks have been written as efficiently as possible without jeopardizing code stability. Blocks are written in one standard language, and the interface between blocks is well defined. Unwanted interactions between unrelated pieces of software, while common in many other control systems, have virtually been eliminated with the GAP software.

The timing requirements of the code generated by the GAP software have also been rigidly defined and adhered to. Variable execution time blocks have been avoided. Woodward software guarantees that a task programmed to run every 5 ms (or whatever the assigned recursion rate), will run exactly every 5 ms, no matter what other functions the control system is presently exercising. Most systems based on PLCs cannot do this. The non-variability in the execution times of the blocks means that a control which runs efficiently on a test stand is currently exercising the entire control program. The user does not have to worry that under an unanticipated set of conditions, the processor will become overburdened and will not have enough time to complete its assigned tasks. Only with predictable execution times can a multitasking operating system have a guaranteed update rate.

Powerful Block Language

Because of Woodward's longstanding relationship with turbine OEMs, special software algorithms have been written and verified through years of use in the field.

These special blocks include:

- A unique PID algorithm with special provisions for disturbance handling and noise rejection
- Anti-reset wind-up low-signal-select and high-signal-select blocks
- Extraction/de-coupling algorithms
- Special acceleration controls for precise turbine start-ups
- Special algorithms that allow parallel or series valve transfers with minimal bumping
- Compressor surge control algorithms
- Several modes available for bumpless transfer between control modes
- Special disturbance rejection algorithms for step load changes
- Model reference controls for special turbine system problems
- Sequencer Function Chart (SFC) blocks for building state machines
- Modular software structure allows extensive software code reuse
- Core fuel control modules reduce system programming times while increasing software quality

The same code produced by the GAP software is used in a wide variety of Woodward platforms from low-end low-cost controls to high-end fault-tolerant systems.

Here are just some of the Woodward products that are programmed using GAP:

MicroNet™, MicroNet TMR®, NetCon®, Atlas Series Controllers, In-Pulse™, EGCP Series Controllers, PCMHD Controllers, Eagle Valve Controllers, easYgen™ Controllers, ECM3 Controllers, MCU Controllers

Powerful Editing Features (version 3.0 & above)

- Project organized into modules which can each be given different view, edit and build permissions. Protected with AES (Advanced Encryption Standard)
- Powerful error checking including instantaneous passive error reporting
- Self-maintaining input and output references which function like HTML links
- Search and select dialogs with powerful filtering, sorting and pattern-matching capabilities
- Edit multiple congruent items at once
- Deep undo/redo and navigation history queues
- Automatic change-logging in published modules

System Support and Modification

During system support and modification, the advantages of the GAP software become readily apparent. Because of the structure of the GAP software, and because it generates its own documentation, user changes to the control software can be performed by field service personnel. If the control system software were written with only the aid of a software compiler like C or Pascal, any errors introduced in this code by users would be difficult to identify and repair. The GAP system generates its own documentation that is guaranteed to match the control code generated. Only with a tool like this can user-modified software be supported by anyone other than that user.

Because of its rigidly defined nature, the GAP system allows Woodward to exercise the same engineering change and revision control system procedures that are used to control the manufacture of any control system part. This ISO 9001 approved engineering change system guarantees software compatibility, as well as documentation that makes it possible to reproduce,

diagnose, and repair control logic bugs. Changes made to published applications are automatically recorded, tagged and time-stamped. If any logic bugs are entered, they will be well documented, and the affected systems will be easily located and corrected.

Additionally, GAP is completely compatible with NetSim, Woodward's simulation software that provides an environment in which engineers can thoroughly test the application program against a virtual model of the target hardware. NetSim accurately simulates the deterministic scheduling of GAP blocks, so system dynamics can be analyzed in simulation. This allows safe and very cost effective troubleshooting of the application without hardware in the loop.

The GAP program comes with the Control Assistant live value viewing and maintenance tool. An additional license may be purchased to view these values in a moving trend. In context live value monitoring is also available in the GAP program with the purchase of a Monitor GAP license.

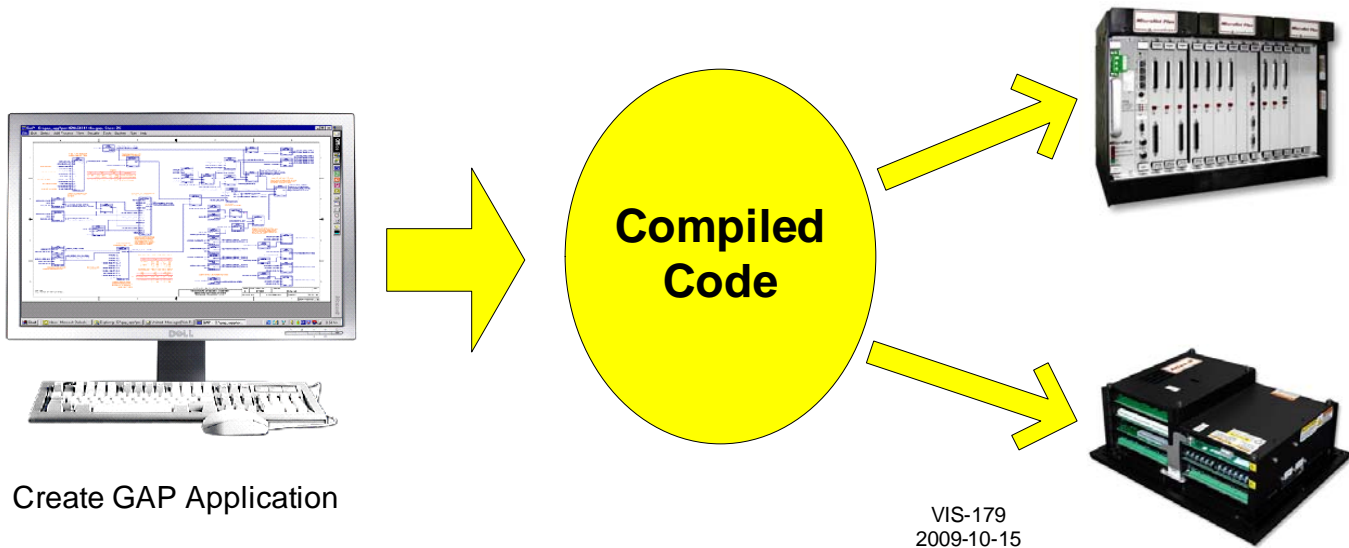

PO Box 1519, Fort Collins CO, USA 80522-1519
 1000 East Drake Road, Fort Collins CO 80525
 Tel.: +1 (970) 482-5811 ♦ Fax: +1 (970) 498-3058
www.woodward.com

Distributors & Service

Woodward has an international network of distributors and service facilities. For your nearest representative, call the Fort Collins plant or see the Worldwide Directory on our website.

This document is distributed for informational purposes only. It is not to be construed as creating or becoming part of any Woodward contractual or warranty obligation unless expressly stated in a written sales contract.

Copyright © Woodward 2009, All Rights Reserved

For more information contact:



U.S. Toll Free 877-544-5201
 Lada S/C Mexico 888-418-DRAK (3725)
www.drakecontrols.com